

80mm Dial Stainless Steel Case

Model 17P, 17b & 17H

The model 17P is manufactured to meet the demand for small high quality gauges designed for multiple applications except gases, (over 25 bar) to include water or any liquid that does not attack copper and bronze. The instruments are available in 80mm dial size with either direct or surface mounting options. They are suitable for solvent laden or chemical laden atmospheres that could damage a polycarbonate case. The case is polished stainless steel and the front window is retained by a ring of white Hytrel polyester.

The window can be either glass or perspex depending on the application. These instruments are produced to look exceptionally clean and bright in appearance and can be used in areas where appearance is a critical factor for aesthetics.



Size

80mm dial diameter

Mounting

Direct bottom, bottom-back or surface

Case & Bezel

Stainless Steel polished case with Hytrel polyester retainer (bezel)

Scale Ranges

Up to 600 psi - Phosphor Bronze Tube **Model 17P**
Up to 4,000 psi - Beryllium Copper Tube **Model 17B**
Up to 10,000 psi - High pressure Stainless Steel coil tube **Model 17H**

Pressure Element

Dependent on range - see above

Overload

Units will withstand up to 125% of FSD

Pressure Connection

1/4" BSP as Standard (NPT also available)
1/8" & 3/8" BSP & NPT are also available
Also available with a diaphragm seal assembly.

Accuracy Class

CL:1 1.0% of FSD as defined in EN837-1

Temperature

Operating: -20 to +90 °C
Storage: -40 up to +100 °C
Options: for lower or higher operating temperatures

Temperature Effect

Variation in indication caused by temperature shall not exceed $\pm 0.04 \times (t_2 - t_1)\%$ of the span where:
t1 is the reference ambient temperature in degrees Celsius
t2 is the ambient temperature in degrees Celsius

Dial

White Anodised Aluminium marked in black finish
Option: Dual scale, colour bands & sectors
Customisation with Company Name & Logo also available

Pointer

Aluminium coloured black

Movement

Brass Construction
Option : Viscous Damped movement to overcome the effects of minor pressure pulsations and vibrations

Window

One Piece Polycarbonate

Environmental Rating

IP54 as defined in EN 60 529

Traceability

All instruments are individually calibrated and have a unique Serial Number printed on the dial. A Certificate of Conformity Traceable to National Standards is Supplied Free of Charge

Certification Available

BS EN 10204 3.1 Material Certification
Point by Point Test Certificate

Safety

All units are manufactured to comply with EN 837-1, O specification and other regulatory standards including PED. Blow-out vent design = S2 safety specification.

Installation Instructions

Refer to EN 837-2

Special Scales

Customised dials and scales are available.



Authorised Australian distributor for



Dimensions

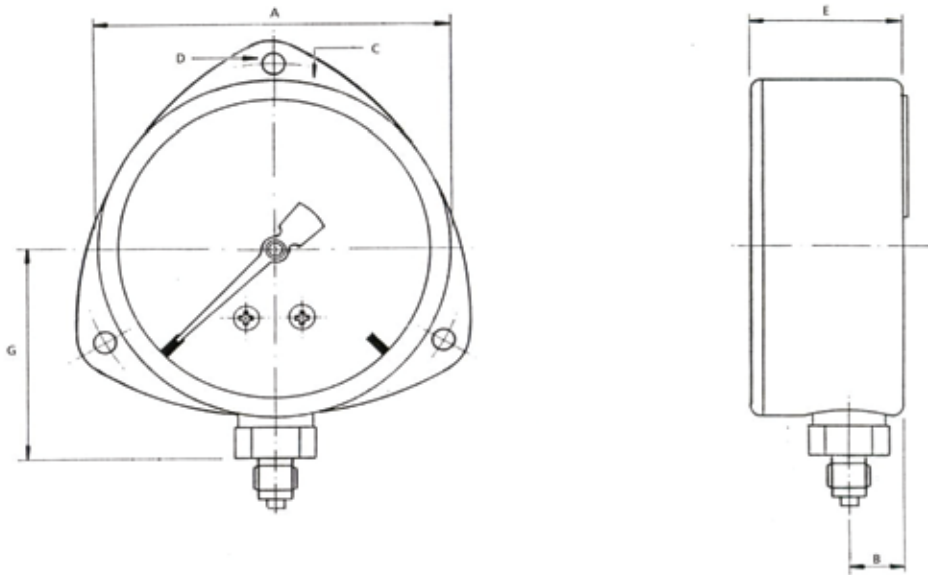

Model No 17P	A	B	C	D	E	F	G	Weight
80mm Steel Case	83mm	14mm	91mm	5.5mm	36.5mm	153mm	51.5mm	0.4kg

Blow-out disc version for S2 specification

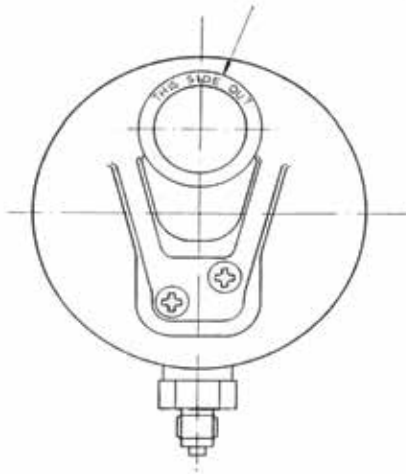

Options

- Case: Customer Name or Logo
- Mounting: See other data-sheets for other styles
- Threads: NPT Available
- Dials: Colour Sectors

Accessories

For high temperature applications such as steam, see our range of syhons and adaptors. Also refer to separate data sheets for gauge cocks and needle valves/manifolds.

Authorised Australian distributor for



Procon Instrument Technology

1 / 119 Delta Street Geebung QLD4034

07 3823 1922

sales@proconit.com.au www.proconit.com.au

PIT_17P-17H-17B-80mm-Pressure-Gauge_v1.0